



## VC850MZ-MODULE

- VCSEL Module
- 850 nm, max. 10 mW
- Multi-Mode
- Without Driver
- Glass Lens, Focus Adjustable



### Description

**VC850MZ-Module** is a VCSEL module emitting at 850 nm with rated output power of max. 10 mW. It features a black anodized aluminium casing with an adjustable 3-glass collimator lens. **VC850MZ-Module** comes without driver electronics.

### Maximum Ratings

| Parameter                        | Symbol     | Values |       | Unit |
|----------------------------------|------------|--------|-------|------|
|                                  |            | Min.   | Max.  |      |
| Forward Current                  | $I_F$      |        | 50    | mA   |
| Reverse Voltage                  | $V_R$      |        | 5     | V    |
| Operating Temperature            | $T_{CASE}$ | 0      | + 60  | °C   |
| Storage Temperature              | $T_{STG}$  | - 40   | + 100 | °C   |
| Soldering Temperature (max. 10s) | $T_{SOLD}$ |        | 260   | °C   |

### Specifications ( $T_{CASE}=25^{\circ}C$ )

| Parameter          | Symbol          | Values                    |      |      | Unit     |
|--------------------|-----------------|---------------------------|------|------|----------|
|                    |                 | Min.                      | Typ. | Max. |          |
| Peak Wavelength    | $\lambda_P$     | 840                       | 850  | 860  | nm       |
| Optical Power      | $P_O$           |                           |      | 10   | mW       |
| Spectral Width     | $\Delta\lambda$ |                           |      | 0.85 | nm       |
| Output Aperture    |                 |                           | Ø5   |      | mm       |
| Threshold Current  | $I_{TH}$        |                           | 8    |      | mA       |
| Forward Current    | $I_F$           |                           | 20   |      | mA       |
| Forward Voltage    | $V_F$           |                           | 1.8  | 2.2  | V        |
| Breakdown Voltage  | $V_B$           |                           | -10  |      | V        |
| Slope Efficiency   | $\eta$          | 0.4                       | 0.9  |      | W/A      |
| Dynamic Resistance | $R_D$           |                           | 13   | 20   | $\Omega$ |
| Focus              |                 | adjustable                |      |      |          |
| Lens Type          |                 | 3-glass lens, AR coated   |      |      |          |
| Material Body      |                 | Aluminium, black anodized |      |      |          |
| Dimensions         |                 | Ø10 x 18                  |      |      | mm       |
| PIN Leads          |                 | Ø0.45 x 13.5              |      |      | mm       |



## Drawing

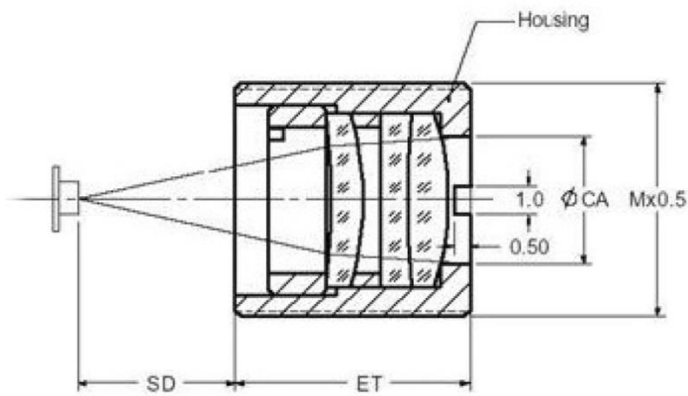
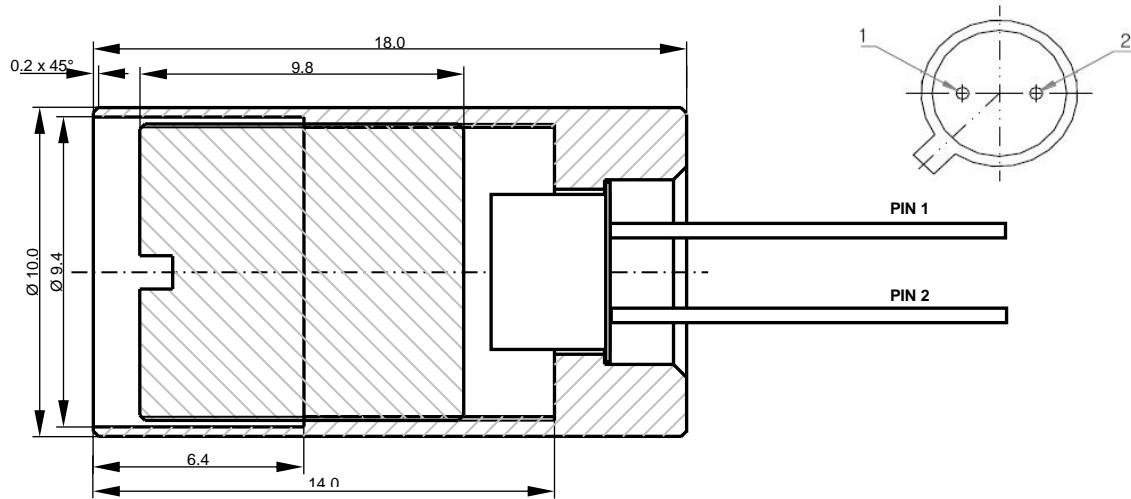

| 3 glass lens |              |
|--------------|--------------|
| EFL          | 8.0 mm       |
| SD           | 3.1 mm       |
| NA           | 0.298        |
| CA           | 5.0 mm       |
| ET           | 9.8 mm       |
| Housing      | M9 x 0.5     |
| AR coating   | 630 – 670 nm |

All dimensions units are mm

## Electrical Connection

| Lead  | Description |
|-------|-------------|
| PIN 1 | Anode       |
| PIN 2 | Cathode     |

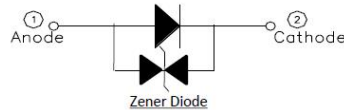

## Additional Information





## Precaution for Use

### 1. Cautions

DO NOT look directly into the emitted light or look through the optical system. To prevent in adequate exposure of the radiation, wear protective glasses.

This VCSEL emits concentrated infrared light

### 2. Lead Forming

- When forming leads, the leads should be bent at a point at least 3 mm from the base of the lead. DO NOT use the base of the lead frame as a fulcrum during lead forming.
- Lead forming should be done before soldering.
- DO NOT apply any bending stress to the base of the lead. The stress to the base may damage the VCSEL's characteristics or it may break the VCSELS.
- When mounted the VCSELS onto the printed circuit board, the holes on the circuit board should be exactly aligned with the leads of VCSELS. If the VCSELS are mounted with stress at the leads, it causes deterioration of the lead and it will degrade the VCSELS.

### 3. Soldering Conditions

- Solder the VCSELS no closer than 3 mm from the base of the lead.
- DO NOT apply any stress to the lead particularly when heat.
- The VCSELS must not be reposition after soldering.
- After soldering the VCSELS, the lead should be protected from mechanical shock or vibration until the VCSELS return to room temperature.
- When it is necessary to clamp the VCSELS to prevent soldering failure, it is important to minimize the mechanical stress on the VCSELS.
- Cut the VCSEL leads at room temperature. Cutting the leads at high temperature may cause the failure of the VCSELS.

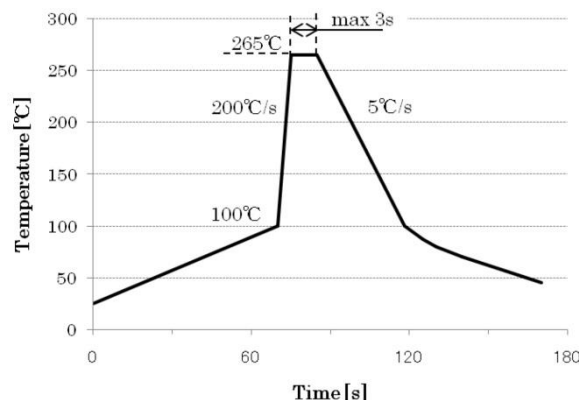

### 4. Static Electricity

- The VCSELS are sensitive to Static Electricity and surge voltage. So it is recommended that a wrist band or an anti-electrostatic glove be used when handling the VCSELS.
- All devices, equipment and machinery must be grounded properly. It is recommended that precautions should be taken against surge voltage to the equipment that mounts the VCSELS.